

» Hardware

Built-in Programmable Logic Controller (PLC)

Built-in PLC set provides customized solutions which support wide coverage from small/middle – to large size-system.



Standard : RS-485
Optional : Profibus, DeviceNet, Modbus, Metasys N2, LonWorks

PLC set, made by LSIS, is the next-generation solution with a new concept providing advanced engineering environment based on open network, fastest processing speed, compact size and user-friendly software.



» Monitoring

Human Machinery Interface(HMI)

Touch screen for MV drive contains a brand new HMI product with an intensive and advanced technology of LSIS to cope with the rapidly changing market situation. It is an innovative product having both reliability and convenience based on Windows CE.

We are confident of our HMI which provides high technology and our commitment to quality of MV drive market.



External Interface

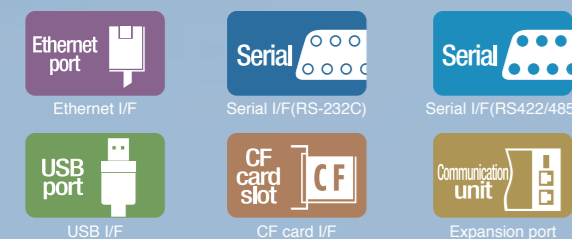

- 12.1 inch touch screen.
- High and vivid distinction with 65,536 colors.
- Read function of a controller's state information.
- Strengthened data management(Logging, Recipe, and Alarm).
- With the user-oriented convenience, it offers high resolution display, prompt data transmission and processing, and a user-friendly interface.

Leading Solution for Your Investment
Leading Solution for Your Development
Leading Solution for Our Environment



LSIS always focuses on environment-friendly devices and energy management system to minimize greenhouse gas emission, waste of energy, and environmental pollution.

LSIS has been manufacturing drive solution for more than 30 years. This experience provides convenience and high efficiency that anytime, anywhere, anyone can use.



Safety Instructions

- For your safety, please read user's manual thoroughly before operating.
- Contact the nearest authorized service facility for examination, repair, or adjustment.
- Please contact a qualified service technician when you need maintenance. Do not disassemble or repair by yourself!
- Any maintenance and inspection shall be performed by the personnel having expertise concerned.



LSIS Co., Ltd.

© 2009.03 LSIS Co., Ltd. All Rights Reserved.

www.lsis.biz

■ HEAD OFFICE

LS Tower, 127, LS-ro, Hogue-dong, Dongan-gu, Anyang-si, Gyeonggi-do 431-848, Korea

- EMEA +82-2-2034-4901 / bonseongk@lsis.biz
- Asia Pacific +82-2-2034-4620 / mswoo@lsis.biz

■ Global Network

- **LSIS (Middle East) FZE >> Dubai, U.A.E.**
Address: LOB 19 JAFZA VIEW TOWER Room 205, Jebel Ali Freezone P.O. Box 114216, Dubai, United Arab Emirates
Tel: 971-4-886 5360 Fax: 971-4-886-5361 e-mail: jungyong@lsis.biz
- **Dalian LSIS Co., Ltd. >> Dalian, China**
Address: No.15, Liaohexi 3-Road, Economic and Technical Development zone, Dalian 116600, China
Tel: 86-411-8273-7777 Fax: 86-411-8730-7560 e-mail: ltxk@lsis.com.cn
- **LSIS (Wuxi) Co., Ltd. >> Wuxi, China**
Address: 102-A, National High & New Tech Industrial Development Area, Wuxi, Jiangsu, 214028, P.R.China
Tel: 86-510-8534-6666 Fax: 86-510-522-4078 e-mail: xuhg@lsis.com.cn
- **LSIS-VINA Co., Ltd. >> Hanoi, Vietnam**
Address: Nguyen Khe - Dong Anh - Ha Noi - Viet Nam
Tel: 84-4-882-0222 Fax: 84-4-882-0220 e-mail: srj@lsisvina.com
- **LSIS-VINA Co., Ltd. >> Hochiminh, Vietnam**
Address: 41 Nguyen Thi Minh Khai Str. Yoco Bldg 4th Floor, Hochiminh City, Vietnam
Tel: 84-8-3822-7941 Fax: 84-8-3822-7942 e-mail: stpark@lsisvina.com
- **LSIS Tokyo Office >> Tokyo, Japan**
Address: 16th, Higashi-Kan, Akasaka Twin Tower, 2-17-22, Akasaka, Minato-ku, Tokyo, Japan
Tel: 81-3-3582-9128 Fax: 81-3-3582-2667 e-mail: jschuna@lsis.biz
- **LSIS Shanghai Office >> Shanghai, China**
Address: Room E-3, 12th Floor Huamin Empire Plaza, No.726, West Yan'an Road Shanghai 200050, P.R.China
Tel: 86-21-5237-9977 (609) Fax: 86-21-5237-7191 e-mail: jinhk@lsis.com.cn
- **LSIS Beijing Office >> Beijing, China**
Address: B-Tower 17FL Beijing Global Trade Center B/D. No.36, BeiSanHuanDong-Lu, DongCheng-District, Beijing 100013, P.R. China
Tel: 86-10-5825-6025,7 Fax: 86-10-5825-6026 e-mail: cuixiaorong@lsis.com.cn
- **LSIS Guangzhou Office >> Guangzhou, China**
Address: Room 1403, 14F, New Poly Tower 2 Zhongshan Liu Road, Guangzhou, P.R. China
Tel: 86-20-8326-6764 Fax: 86-20-8326-6287 e-mail: linsz@lsis.biz
- **LSIS Chengdu Office >> Chengdu, China**
Address: Room 1701 17Floor, huaminhanjun international Building, No1 Fuxing Road Chengdu, 610041, P.R. China
Tel: 86-28-8670-3101 Fax: 86-28-8670-3203 e-mail: yangcf@lsis.com.cn
- **LSIS Qingdao Office >> Qingdao, China**
Address: 7540, Heixin Guangchang Shenye Building B, No.9, Shandong Road Qingdao 26600, P.R. China
Tel: 86-532-8501-6568 Fax: 86-532-583-3793 e-mail: lrj@lsis.com.cn

Specifications in this catalog are subject to change without notice due to continuous product development and improvement.

Medium Voltage VFD
Perfect Energy Saving Drive

3kV 200kVA ~ 3,700kVA / 4kV 250kVA ~ 4,700kVA
6kV 400kVA ~ 7,500kVA / 10kV 600kVA ~ 11,000kVA
11kV 800kVA ~ 13,000kVA



» Circuit Configuration



Master Control Section

- Easy-to-use high-function keypad on the door
- Touch-screen(HMI) interface on door
- Drive tool runs on PCs that can interface through the RS-485 is standard.

Power Cell Panel

- Easy individual power cell can be drawn out for maintenance.
- Three cells connected in series per single output phase.

Multi-Winding Transformer

Cell input voltage can be connected each terminal and 36pulse/18winding of dry type phase-shift transformer has equipped. Also it has constructed 5% tap for input voltage change.

Easy Maintenance

Power cells can be replaced and maintained individually. The construction designed for single-action mounting and removal reduces the replacement time and facilitates maintenance operations.

Engineered to continue operating through component failures that would completely disable conventional drives. The patented cell-based configuration maximizes availability, letting the customer determine the right time to perform maintenance, while the modular design reduces system repair time to minutes.



6.0 ~ 6.6kV Class

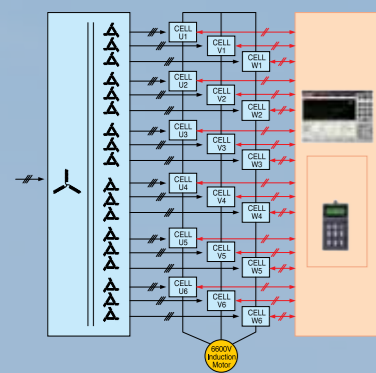

Power Cell

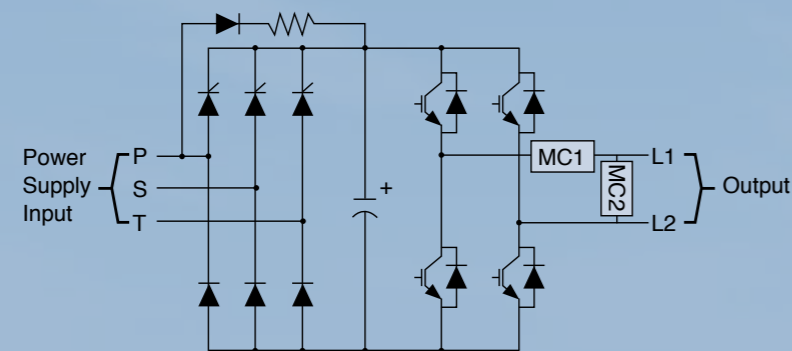

» Fields of Application

Pulp and Paper

- Pumps
- Fans
- Refiners

Chemical, Oil and Gas

- Mixers/Agitators
- Fans/Compressors
- Pumps

Water and Waste

- Water Management
- Pumps

Cement and Mining

- Mills
- Conveyors
- Fans/Exhausters
- Pumps

Sugar

- Sugarcane Mills
- Fans/Exhausters
- Pumps
- Preparation

Pumps

LSIS' unequalled experience was used to make MV Drive the perfect match for pump application. With a wide range of powerful standard features designed specifically for pump application, LSIS MV Drive provides the lowest overall cost of ownership of any drive available.

Fans

LSIS MV Drive offers ease of setup and comprehensive fan and motor protection features. LSIS MV Drive can be configured for Simplex, Duplex or Triplex fan system applications. One MV Drive can be used as a master, which can also control one or two secondary fan motors. The secondary pump motors can be connected using mechanical motor starters, reduced voltage soft starters, or additional MV Drives. The most efficient method is fan speed control that will reduce energy consumption, while maintaining system optimization through LSIS MV Drive.

Mills

The speed of the mill can be accurately controlled by LSIS MV Drive depending on the amount of objects coming into the machine. This is a great advantage compared to the use of the steam turbines and DC motors.

Another advantage is that the electrical drives can estimate the shaft torque and protect the mill against overload. In this case the mill can be driven in reverse to get the excess material out of the machine and resume normal operation with minimum production loss.

Furthermore, after shut down, the cane mill driven by LSIS MV Drive returns to operating conditions much faster than the steam turbine driven mill. Finally, LSIS MV Drive, the noise level is considerably reduced for both MV Drive and the motors and is almost negligible compare to that of steam turbine.

» Service and Support

Testing

LSIS is committed to ensuring the reliability of every drive it delivers. To verify that quality standards and customer requirements are fully met every component of a drive is subjected to thorough testing in optimized test facilities of LSIS.

Installation and Commissioning

Proper installation and commissioning of the equipment, done by qualified and certified commissioning engineers, reduces start-up time, increases safety and reliability and decreases life cycle costs. In addition, operators can be given practical training by experienced specialists on site.

Training

LSIS provides extensive training for its MV Drives. A range of training programs is offered from basic tutorials to programs tailored to the customer's specific needs.

Life-Cycle Management

LSIS is committed to providing complete life-cycle support. We never relinquish the responsibility for servicing our products to your full satisfaction, regardless of the age of the product. To extend the life span and increase the functionality of the drive, the LSIS refurbishment program gives you the opportunity to upgrade the MV drives with new technology as it becomes available.

» Technical Specification

Main power Supply	Voltage	3.3kV, 4.16kV, 6.6kV, 10kV, 11kV		
	Frequency	50Hz, 60Hz		
General Specification	Efficiency	Approx. 98.5% (At rated motor speed, 100% load)		
	Power Factor	Approx. 95.5% (At rated motor speed, 100% load)		
	Cooling Method	Forced air-cooling by fan		
	Input Current THD	Satisfies IEEE Standard		
	Input Transformer	Class H dry type, secondary multi-phase winding		
	Monitoring	12.1 inch HMI touch screen		
Control Specifications	Communication	Standard: RS-485, Option: Profibus, DeviceNet, Modbus, Metasys N2, LonWorks		
	Control Method	V/f, Sensorless Vector		
	Switching Device	IGBT(Insulated Gate Bipolar Transistors)		
	Main Circuit	Multi-level pulse width modulation(Multi-level PWM)		
	Freq. Control Range	0 to 120Hz		
	Drive Type	Voltage Source		
	Freq. Control Accuracy	± 0.1%		
	Freq. Resolution	0.01Hz		
	Accel/Decel Time	0.1 to 6000s		
	Overload Tolerance	120% for 60s		
	Main Control Functions	Synchronous Bypass	Flying start (speed search)	
		Multi Motor Control	Manual and Auto Torque boost	
		PID control	Upper/lower limits for frequency reference	
		Copy function	Local/Remote Operation selection	
Frequency jump		Keypad with LCD + LED displays		
Jog function		Ride-Through (operating during momentary power loss)		
Auto-tuning		Fault Auto-diagnosis and Auto-reset		
Dwell		Independent acceleration and deceleration ramps		
Slip compensation		Direction of Rotation selection(FWD/REV)		
Protective Functions	3-wire sequence	Password to protect drive programming		
	Over current	Cooling-fan trip		
	Overvoltage	Transformer overheating		
	Under voltage	Cell fault		
	Ground fault	Cell overheat		
	Drive overheat	Drive overload		
Maintainability/ Environmental Specifications	Motor overheat	Communications error, etc.		
	Control Panel	Status display, Fault display, Parameter setting, Parameter reference		
	Protection Design	Standard : IP21, Optional : IP52		
	Main Circuit	Power cell construction		
	Ambient Temperature	-5°C ~ +40°C		
Storage Temperature	-20°C ~ +60°C			
Humidity	85%RH max.(no condensing)			